

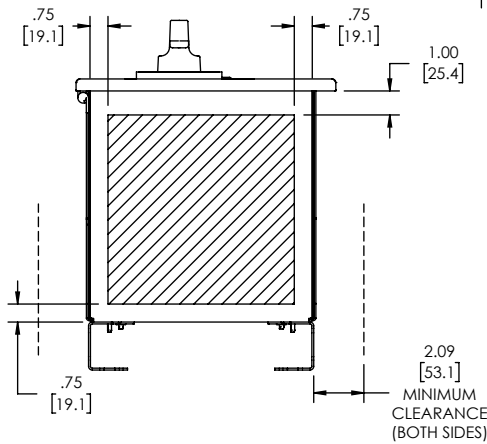

NOTES:

- A. FOR REFERENCE UNLESS PROPERLY ENDORSED. FOR ADDITIONAL DETAILS AND SPECIFICATIONS, CONSULT YASKAWA AMERICA, INC.
- B. DIMENSIONS ARE IN INCHES [MILLIMETERS]
- C. USE APPROPRIATE TYPE RATED HUBS OR FITTINGS TO MAINTAIN ENCLOSURE RATING.
- D. HATCHED AREA INDICATES PERMISSIBLE CONDUIT ENTRANCE AREA.
- E. IF ENCLOSURE IS MOUNTED USING THE MINIMUM SPECIFIED TOP, BOTTOM, LEFT AND RIGHT CLEARANCES, THEN VENTILATION OPENINGS WILL NEED TO BE PROVIDED AT THE CORNERS AS SHOWN ON PAGE 2.

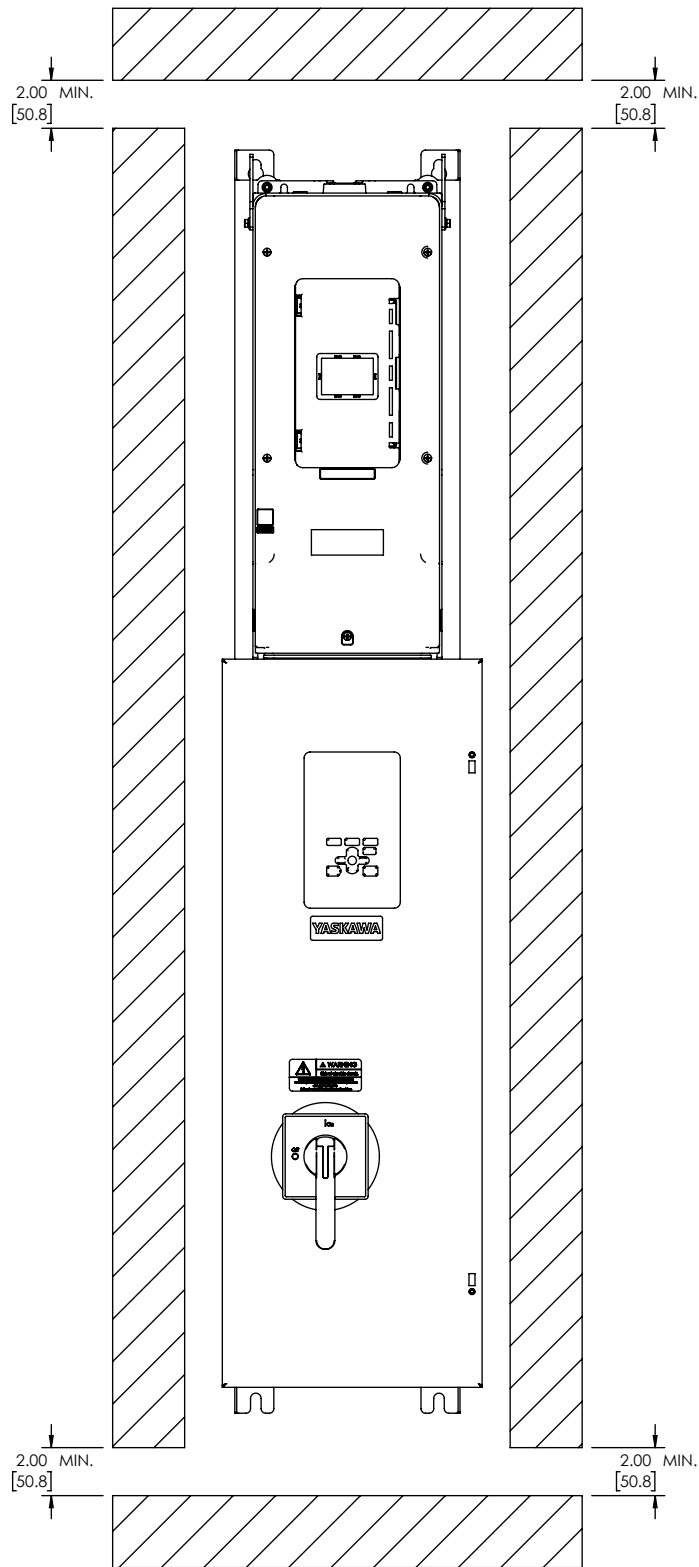

		ORIGINAL DESIGN: D. Guckenberger	DATE: 5/12/2022	TITLE: <b>DIMENSION DRAWING, HV600, NARROW, TYPE 12, BYPASS, W3</b>	
		DRAWN: D. Guckenberger	DATE: 5/16/2022	SIZE: B	REVISION: 01
<small>THIS DOCUMENT AND INFORMATION CONTAINED IN IT ARE CONFIDENTIAL AND CANNOT BE COPIED OR DISCLOSED IN WHOLE OR IN PART WITHOUT THE EXPRESS WRITTEN CONSENT OF YASKAWA AMERICA INC.</small>		CHECKED: P. Johnson	DATE: 5/17/2022	DRAWING #:	
		APPROVED: R. Jensen	DATE: 5/18/2022	DD.HB.12.W3.01	
UNITS: INCHES	SCALE: NONE				



	ORIGINAL DESIGN: D. Guckenberger	DATE: 5/12/2022	TITLE: <b>DIMENSION DRAWING, HV600, NARROW, TYPE 12, BYPASS, W3</b>		
	DRAWN: D. Guckenberger	DATE: 5/16/2022	SIZE: B	REVISION: 01	PAGE: 2 OF 2
<small>THIS DOCUMENT AND INFORMATION CONTAINED IN IT ARE CONFIDENTIAL AND CANNOT BE COPIED OR DISCLOSED IN WHOLE OR IN PART WITHOUT THE EXPRESS WRITTEN CONSENT OF YASKAWA AMERICA INC.</small>	CHECKED: P. Johnson	DATE: 5/17/2022	DRAWING #:		
	UNITS: INCHES	SCALE: NONE	APPROVED: R. Jensen	DATE: 5/18/2022	DD.HB.12.W3.01